

# Panel PC "FlexLine D"

## 12", 15", 17"

### PERFORMANCE

CPU (Intel®)		Core 2 Duo E4300: 2 × 1800 MHz E6400: 2 × 2133 MHz Celeron D 440: 2000 MHz
System memory	optional	1–4 GB DDR2
Internal power supply		250 Watt, 100–240 V <sub>AC</sub>

### LCDs

FlexLine 12"		800 × 600, 180 cd/m <sup>2</sup>
FlexLine 15"		1024 × 768, 250 cd/m <sup>2</sup>
FlexLine 17"		1280 × 1024, 230 cd/m <sup>2</sup>
Touchscreen	optional	resistive or SAW

### SYSTEM DESIGN

Board system class		"industrial grade"
Chipset		Intel® 945G, ICH7
Expansion slots		2 × PCI
Watchdog timer		on board
Ethernet		10/100 Mbit/s, RJ-45, wake-on-LAN support
Graphic		Dynamic Video Memory Technology
Audio		AC97 audio codec

### DRIVES

HDD		80 GB SATA (max. 1000 GB)
HDD type		3.5"
Solid state memory	optional	SSD
CD/DVD ROM	optional	slim type
DVD writer	optional	slim type

### INTERFACES

RS-232		Com1 (Pin9: 5V/12V) Com3 (internal for Touch) Com4 (Pin9: 5V/12V)
RS-232/422/485		Com2 (Pin9: 5V/12V)
Parallel		1
IDE / FDD external		1 × IDE, 1 × FDD
USB front		optional
USB rear		2
PS/2		2
LAN		1 × RJ-45
Graphic		1 × VGA
Other		audio-I/O, DIO port, 5V/12V DC-out

### CONSTRUCTION

Dimensions		see datasheet page 2
Material		heavy-duty steel
Front panels		see Panel-PC options
IP65 protection		optional
VESA mounting		75 × 75 mm connector
Ventilation		CPU and powersupply fan

### QUALITY / TESTS

Burn-in stress test		min. 24 hours
Climatic stress test		40° C ambient temp.
Customer specific tests		optional
Production		ESD protected
Quality management		acc. to ISO 9001:2000
Operating temperature		0–45° C
Warranty		24 months



Since its introduction in 1998 thousands of units have been started up and are now operating as human-machine-interface all over the world with great reliability.

### Front bezels / housing:



**flush**, steel sheet, RAL7035  
**19" / 8U**, steel sheet 3 mm, with or w/o holes, RAL7035  
**IP65 Panelmount**, aluminium 5 mm, IP65 protection, RAL7035  
**IP65 Panelmount Operator** (15"), aluminium 5 mm, with keyboard  
**Full IP65 protection** (FlexLine M), aluminium, RAL 7035 + 5010

### Model names:

12" Core 2 Duo	FlexLine 12-D
15" Core 2 Duo	FlexLine 15-D
17" Core 2 Duo	FlexLine 17-D



Errors and changes excepted

Version 2.8



**TL Electronic GmbH**  
 Bgm.-Gradl-Str. 1  
 85232 Bergkirchen-Feldgeding  
**Germany**  
 Tel. / Fax +49 (0)8131 33204-0 / -150  
[www.tl-electronic.de](http://www.tl-electronic.de)

**TL Electronic GmbH Österreich**  
 Grazer Str. 10  
 8130 Frohnleiten  
**Austria**  
 Tel. / Fax +43 (0)3126 51100-0 / -50  
[www.tl-electronic.at](http://www.tl-electronic.at)

**TL Electronic GmbH Italy**  
 Agency: MEBO srl  
 via Carso 18, 10141 Torino  
**Italy**  
 Tel. / Fax +39 0173 610561  
[www.tl-electronic.it](http://www.tl-electronic.it)

# Panel PC "FlexLine D"

## Dimensions

### 12" FlexLine:

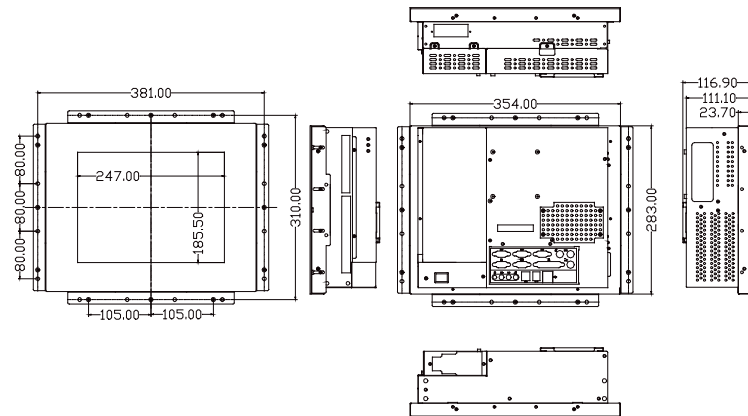

### 15" FlexLine:

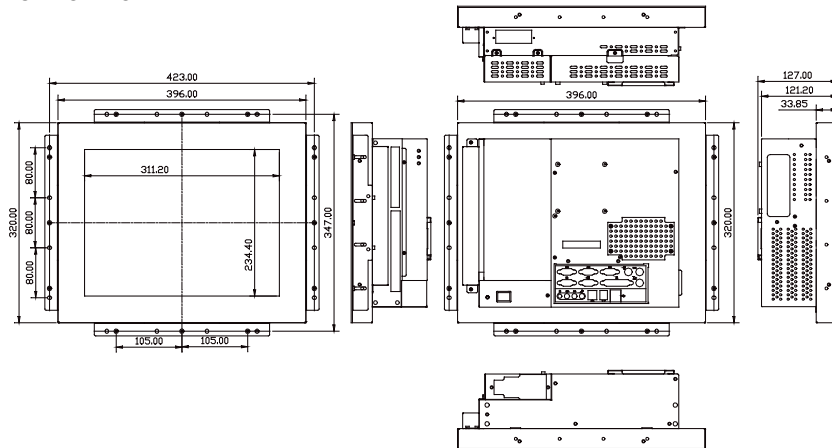

### 17" FlexLine:

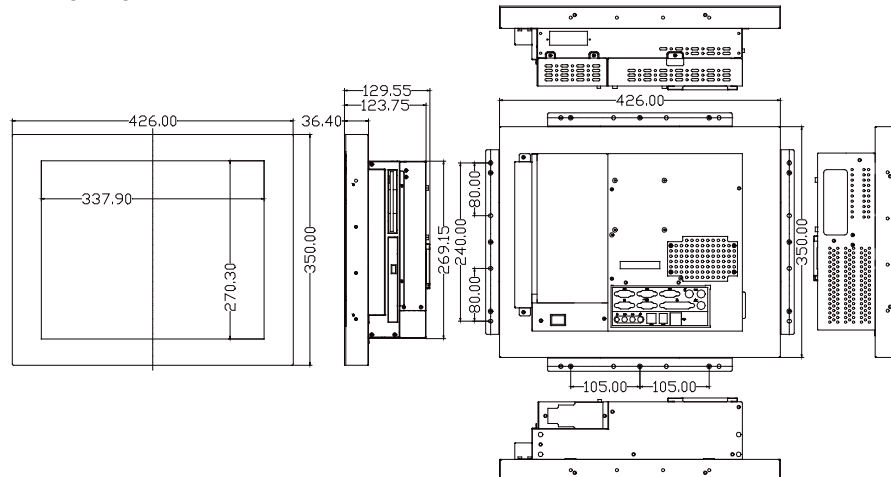

FlexLine can be optionally equipped with FDD and CD/DVD (slim type). The standard version has two expansion slots.



All connections and control elements are located on the back. The power supply unit is integrated into the rugged sheet steel housing of FlexLine.

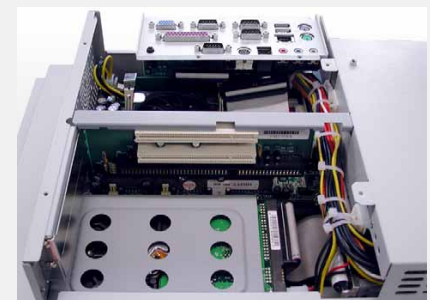

In series, cable routing is constantly effected in the same way. For further increasing the reliability of the panel PCs, as an additional security all cables and moving parts are tightly fixed.