

Panel PC "RuggedLine"

8.4", 10.4"

Intel® Atom
"RuggedLine xx-AT"



PERFORMANCE

CPU		Intel® Atom N270, 1600 MHz
System memory		1 GB / 2 GB DDR2
Power input		12 V _{DC}
	optional	8-36 V _{DC}
Power supply		external power supply incl.
Power consumption		20 W typ.

LCD

8.4"		800 × 600, 350 cd/m ²
10.4"		800 × 600, 400 cd/m ²
Touchscreen	optional	resistive ELO, 5-wire
Transflective LCD	optional	for intense ambient light

SYSTEM DESIGN

Board system class		"industrial grade"
Chipset		Intel® 945GSE & ICH7M
Ethernet		Dual 10/100/1000 Mbit/s
W-LAN	optional	802.11 b/g, SMA antenna
Graphic		224 MB shared memory
Audio		AC97 audio codec

DRIVES

Solid State Disk		CompactFlash "industrial grade"
	10.4"	2.5" SSD "industrial grade"
HDD	10.4"	2.5" "Automotive", 160 GB max.

INTERFACES

RS-232		1 × COM1
RS-232/422/485	optional	1 × COM2
USB		2
PS/2		1
Ethernet		2 × RJ-45
Graphic		1 × VGA
Audio	10.4"	standard I/O

SOFTWARE

Operating systems	optional	Windows® XP Professional, XP Embedded, CE 5.0, Linux
-------------------	----------	--

CONSTRUCTION

Dimensions (WxHxD)	8.4"	277 × 220 × 60 mm
	10.4"	316 × 251 × 67 mm
Material		aluminium, RAL 5001
VESA mounting		75 × 75 mm connector
Mounting set	optional	steel sheet mounting stand
Ventilation		fanless, passive
Controls		frontside: power, reset, brightness, control LEDs

QUALITY / TESTS

Burn-in stress test		min. 24 hours
Climatic stress test		40° C ambient temperature
Customer specific tests		optional
Production		ESD protected
Quality management		according to ISO 9001:2000
Operating temperature		-10-55° C
Ingress protection		IP65, except for I/O area
Shock (operating) *		30 G / 18 ms, 300 m/s ²
Vibration (operating) *		1.60/1.96/2.18 G rms X/Y/Z 5-500 Hz
Certifications		CE, FCC class B
Warranty		24 months

* according to MIL810F and IEC60068-2-27 standards only with solid state memory



The rugged housing is made of durable aluminium die casting with anti-corrosion treatments. It is protected against dirt and water according to IP65 standard except for the interfaces area.

All controls are frontside.

Optional with mounting bracket.

The RuggedLine Panel PC is laid out to work reliably even under the influence of shock and vibration according to MIL810F and IEC60068-2-27 standards.



Interfaces area at the bottom

Fanless Technology:

The system with ultra-low-voltage CPU is cooled passively and needs no cooler fan.

The CPUs and the LCD panels with low power consumption produce minimum waste heat. Durability and system stability benefit from these advantages.

Passive LCD version also available



Errors and changes excepted

Version 1.8



TL Electronic GmbH
Bgm.-Gradl-Str. 1
85232 Bergkirchen-Feldgeding
Germany
Tel. / Fax +49 (0)8131 33204-0 / -150
www.tl-electronic.de

TL Electronic GmbH Österreich
Grazer Str. 10
8130 Frohnleiten
Austria
Tel. / Fax +43 (0)3126 51100-0 / -50
www.tl-electronic.at

TL Electronic GmbH Italy
Agency: MEBO srl
via Carso 18, 10141 Torino
Italy
Tel. / Fax +39 0173 610561
www.tl-electronic.it

Panel-PC RuggedLine

8.4"

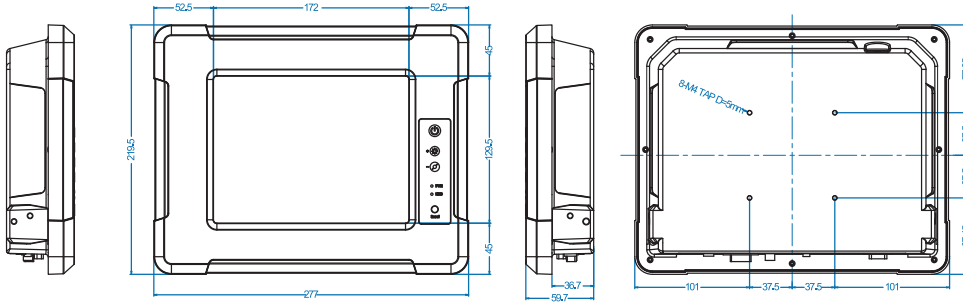

SIDE VIEW

FRONT VIEW

SIDE VIEW

VIEW

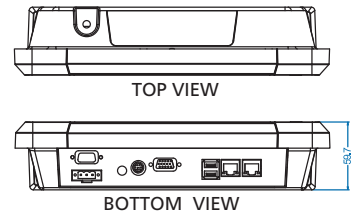

TOP VIEW

BOTTOM VIEW

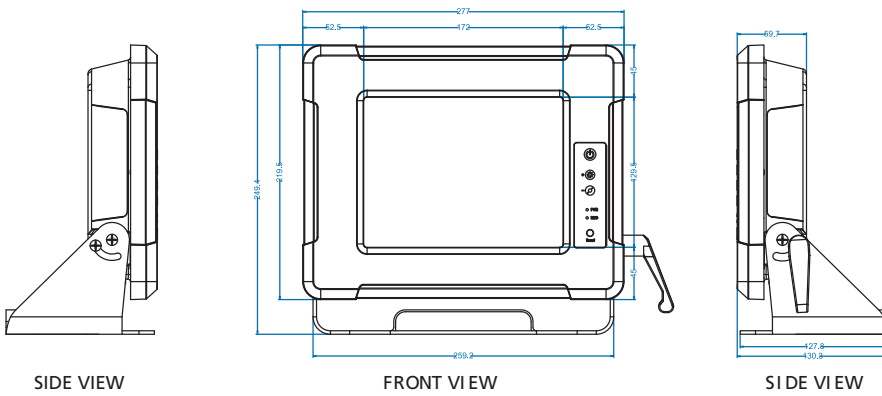

SIDE VIEW

FRONT VIEW

SIDE VIEW

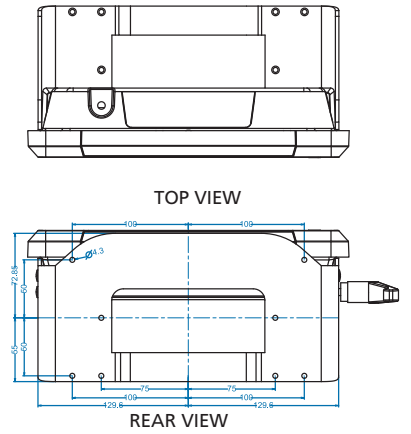

TOP VIEW

REAR VIEW

10.4"

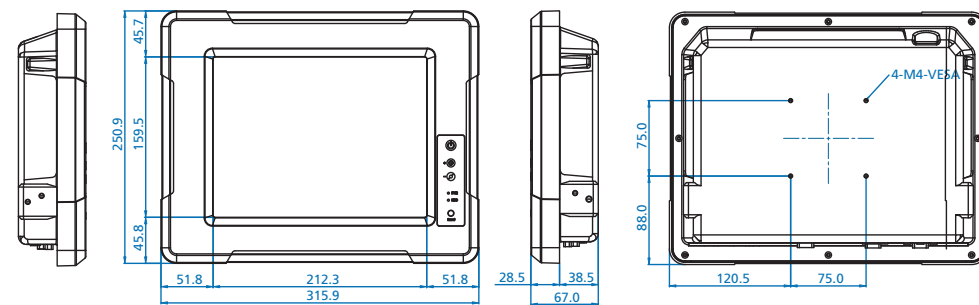

SIDE VIEW

FRONT VIEW

SIDE VIEW

VIEW

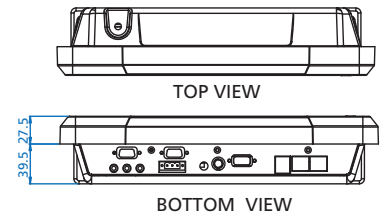

TOP VIEW

BOTTOM VIEW

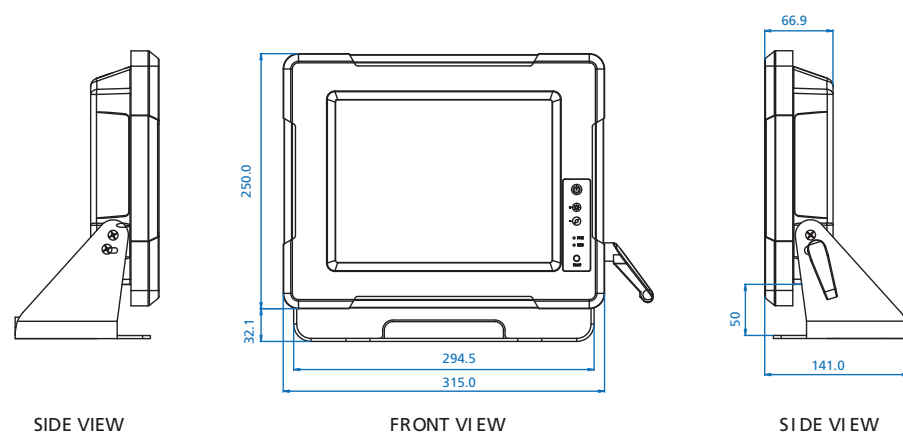

SIDE VIEW

FRONT VIEW

SIDE VIEW

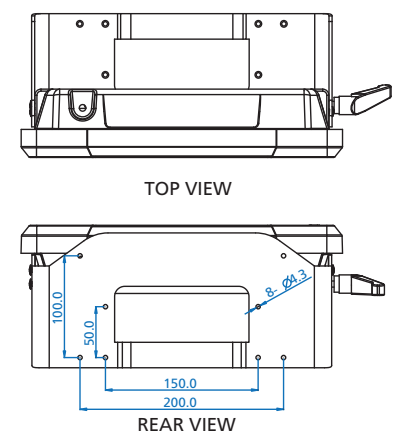

TOP VIEW

REAR VIEW

unit: mm, not to scale